

ASSEMBLY - TCK-FLATTOP/TCK-SIDECAB

1 Install Casters.

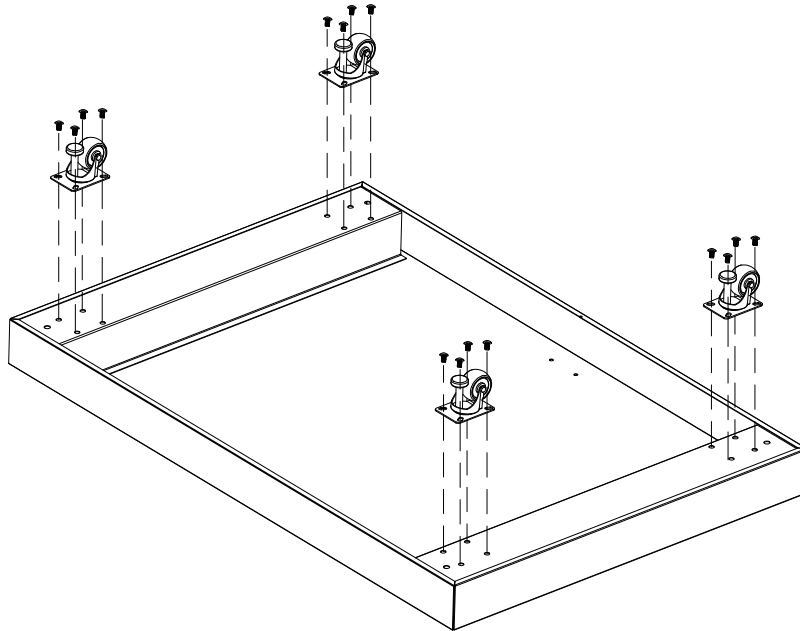

Phillips Head Screw 3/16"x3/8"
Qty.16



2 Install Trolley side panels.



Phillips Head Screw 3/16"x3/8"
Qty.6

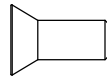

Countersunk flat head screws 3/16" x 3/8"
Qty. 2



Nylon Nut : 3/16"
Qty. 2

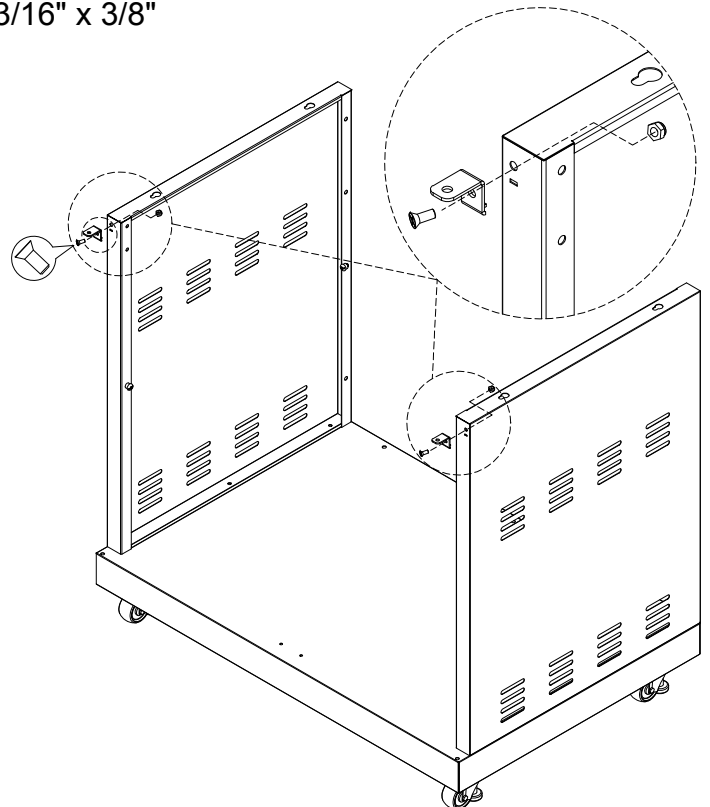
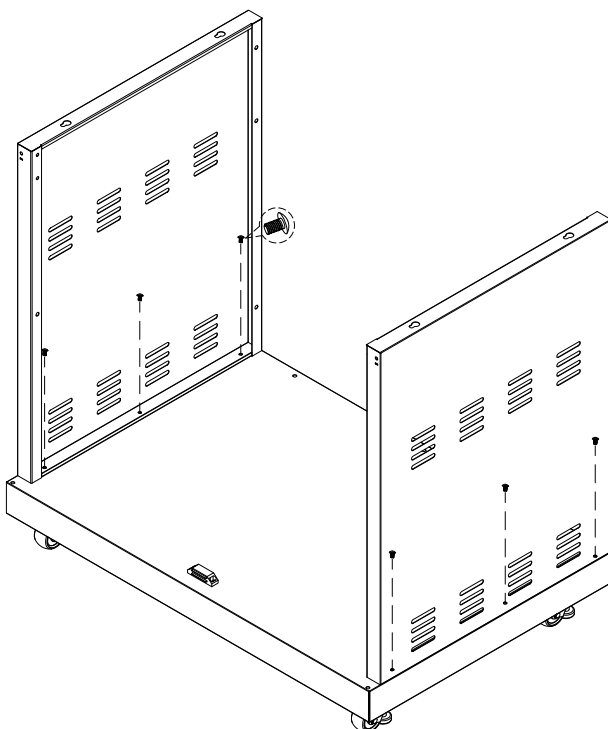

3 Install Trolley Rear panel.



Phillips Head Screw 3/16"x3/8"
Qty.10



Flange Nut 3/16"
Qty.1

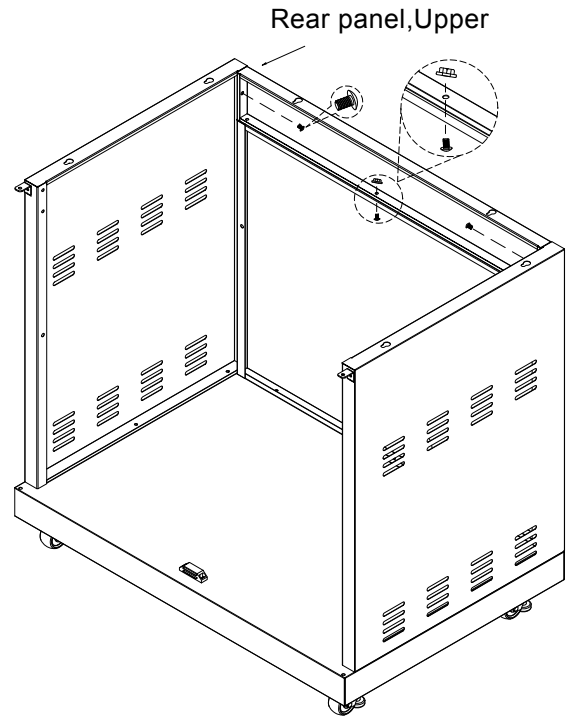
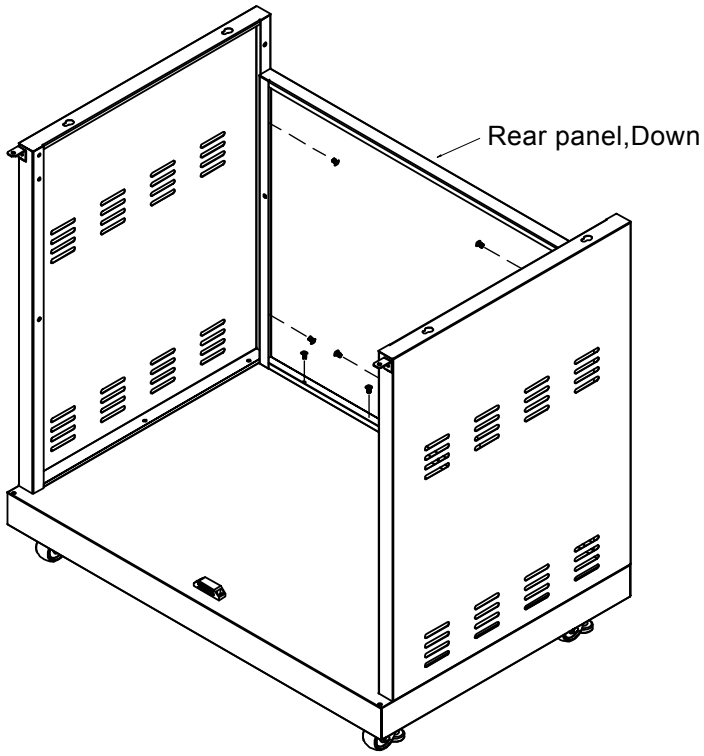

4 Install Door Bracket.



Phillips Head Screw 3/16"x3/8"
Qty.4

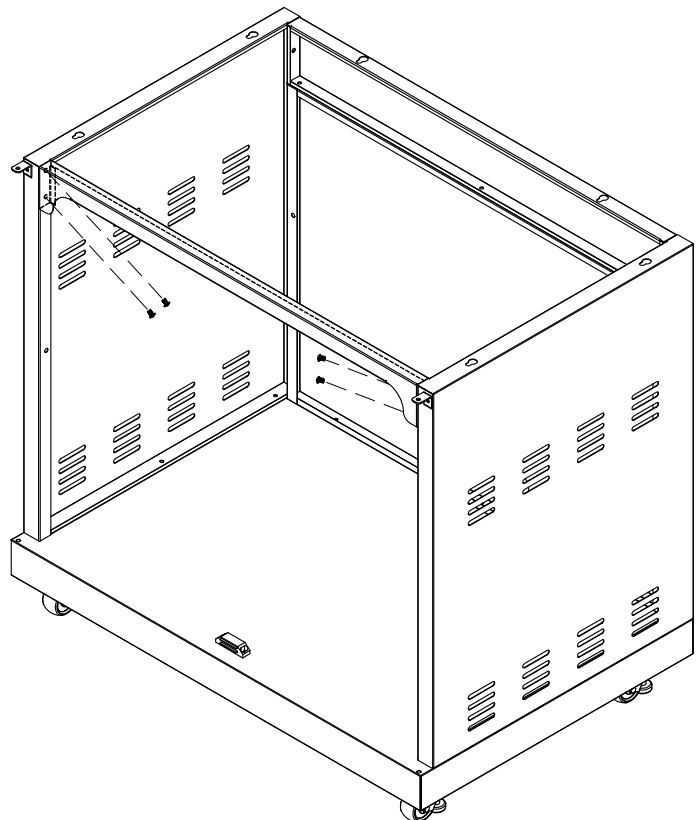

5

Install middle panel.



Bolt screw 3/16"x8mm
Qty.4

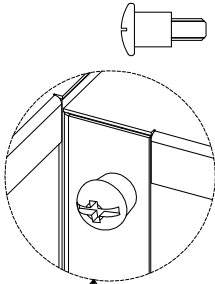

1. Install the screws.

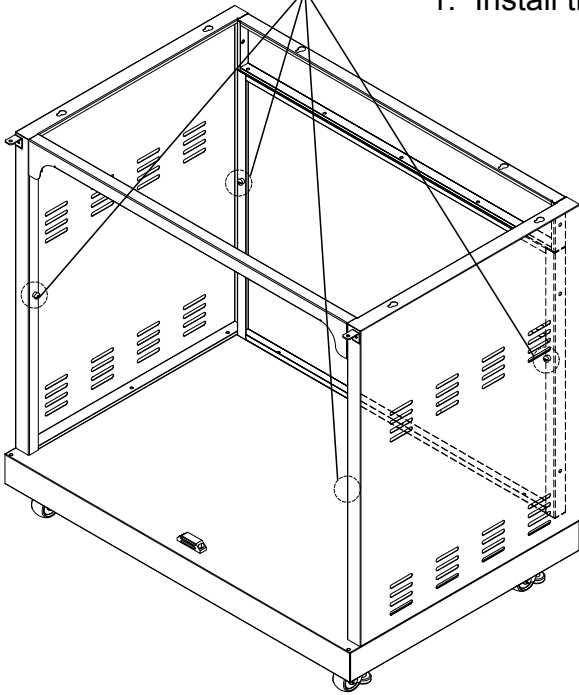

2. Slide in the middle panel.

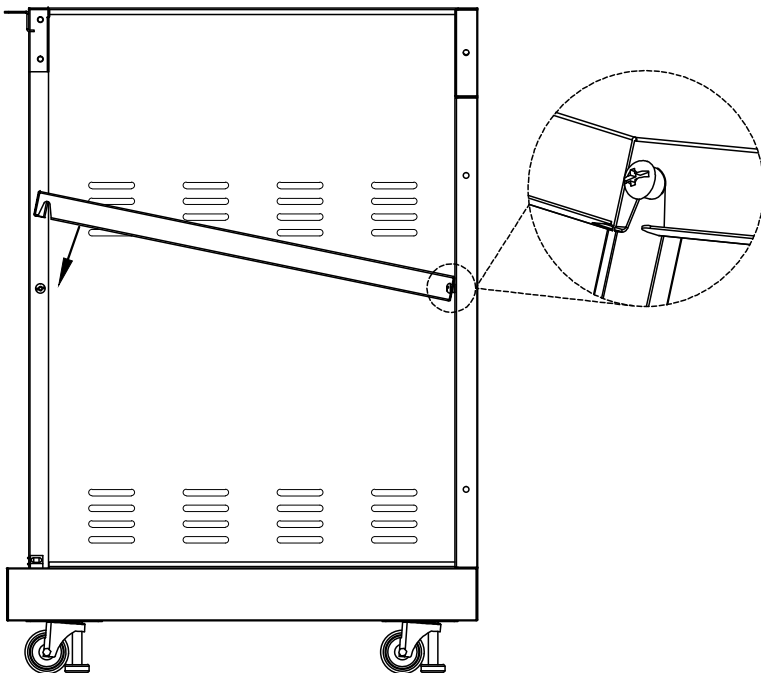
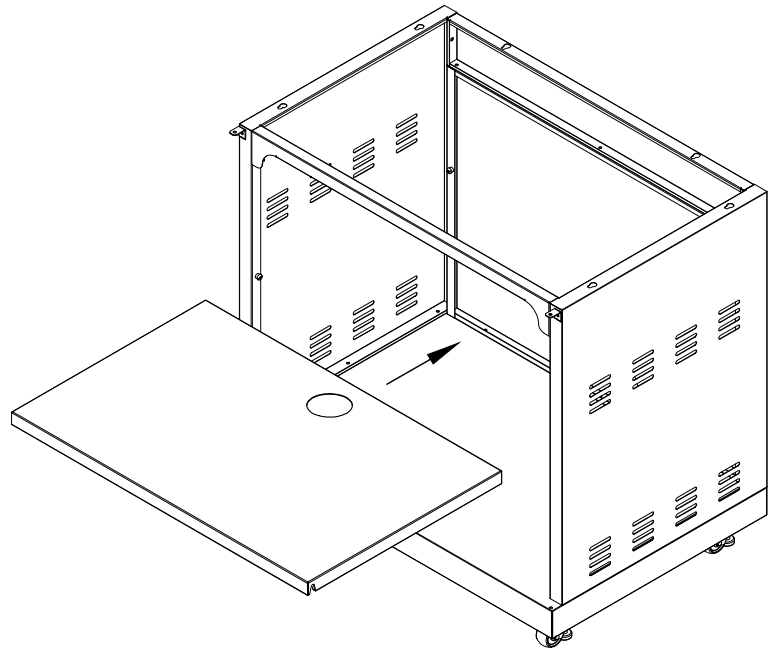

6

Install countertop (TCK-FLATTOP).

Phillips Head Screw M6X10
Qty.6

1. Pre-install the screws partially on the Table plate (Do not tighten to the end).

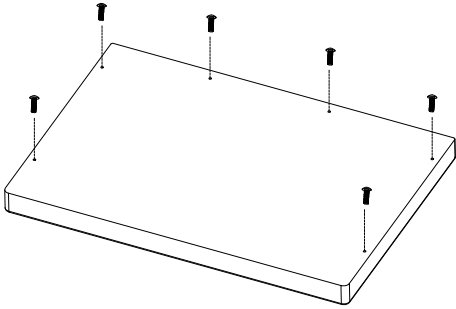

2. Position the pre-installed Screws on the cabinet.

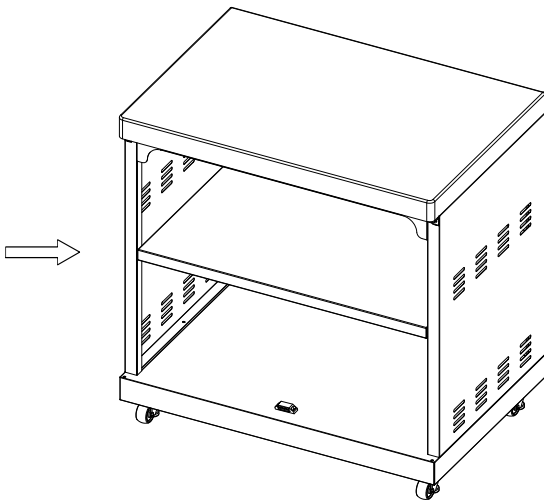
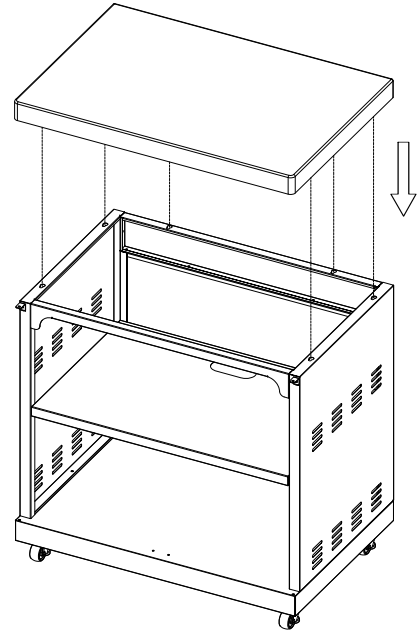

Tighten all screws

Follow the same instruction to install the sink countertop.

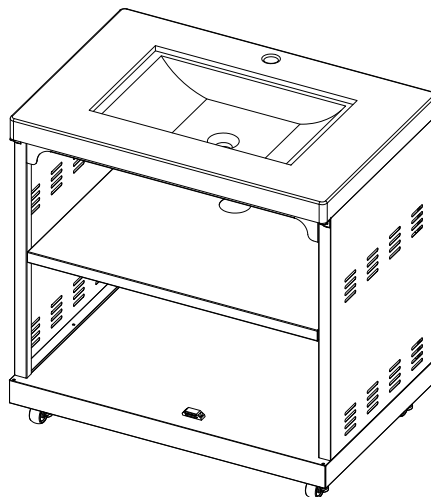
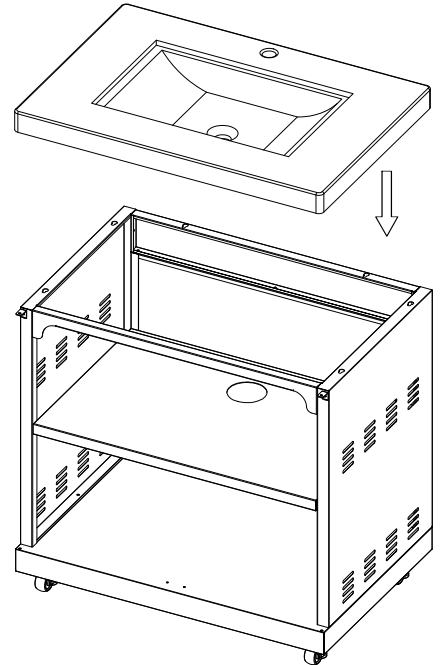

7 Install Door

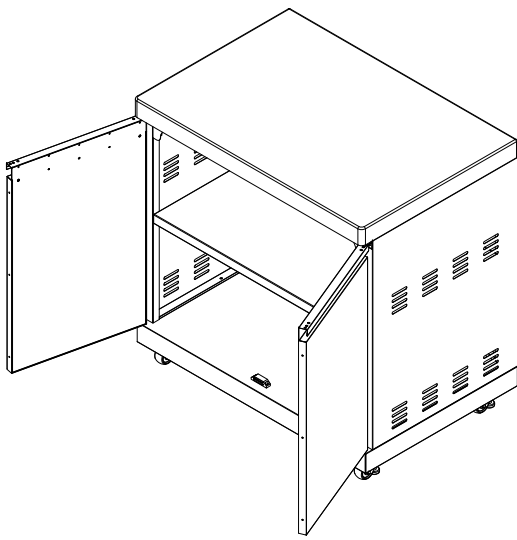

finish

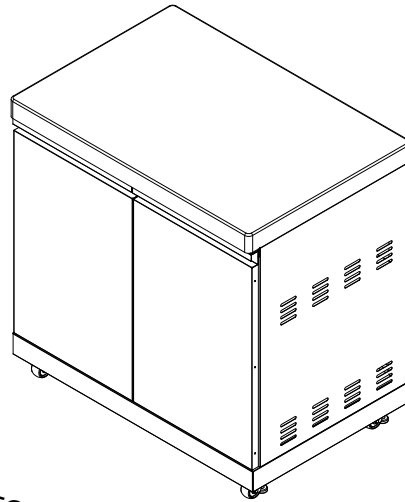

TCK-FLATTOP

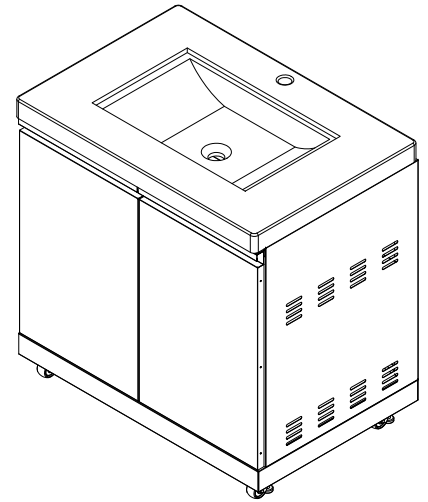

TCK-SIDECAB

ASSEMBLY - TC4K-BBQCAB/ TC2K-BBQCAB

1 Install Casters.



Phillips Head Screw 3/16"x3/8"
Qty.16

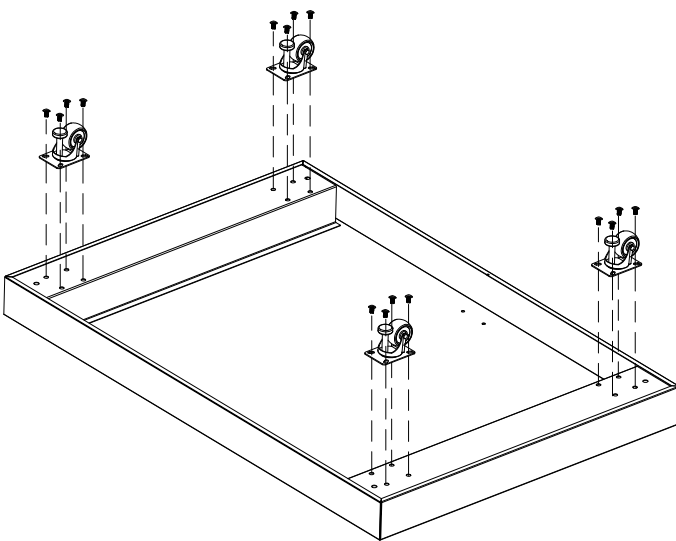

2 Install Trolley side panels.



Phillips Head Screw 3/16"x3/8"
Qty.6

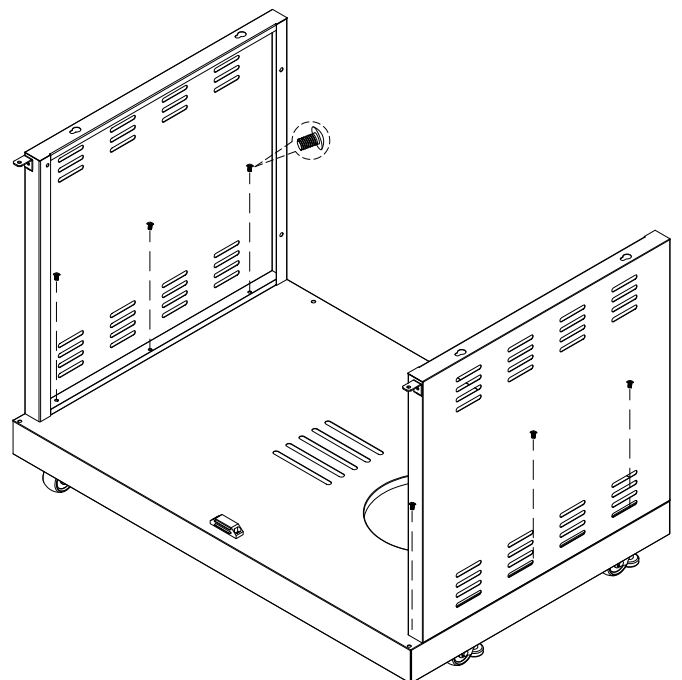

3

Install Trolley Rear panel.



Phillips Head Screw 3/16"x3/8"
4B-Qty.7
2B-Qty.6

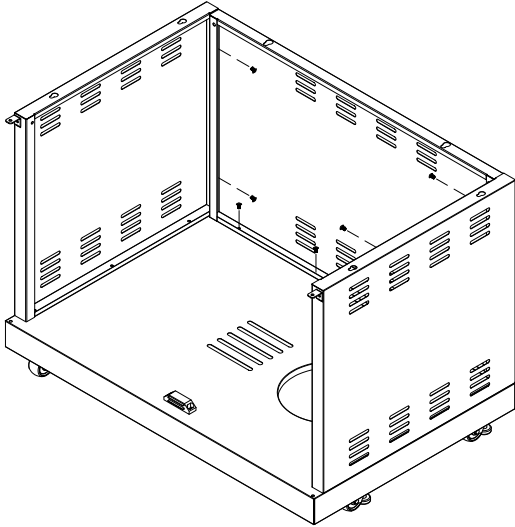

4

Install AGA separation panel .



Bolt screw 3/16"x8mm
Qty.2

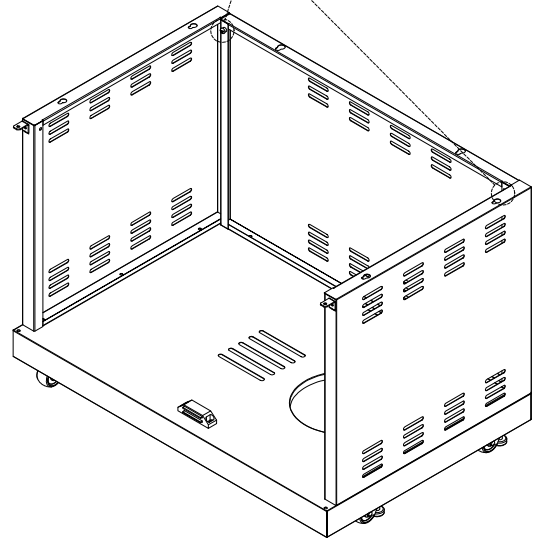
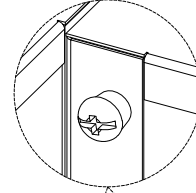

Phillips Head Screw 3/16"x3/8"
Qty.2

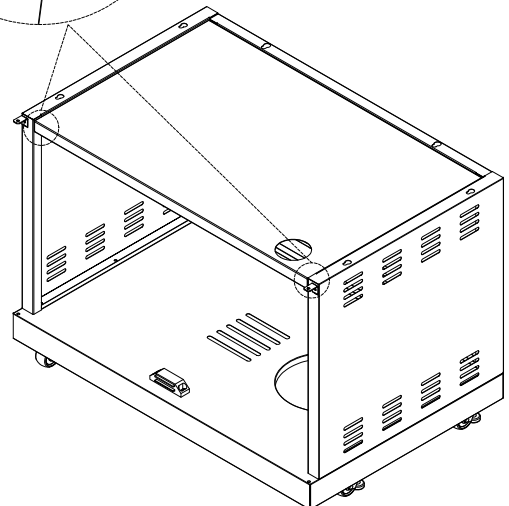
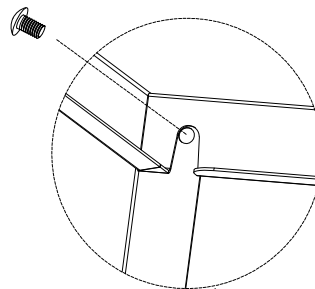
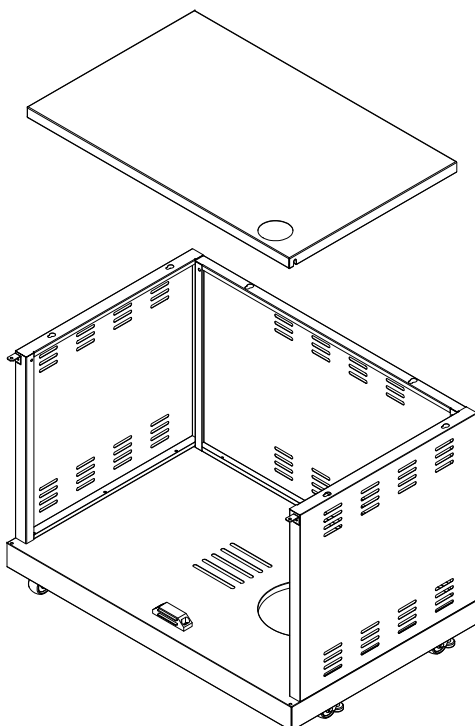

5 Install Door

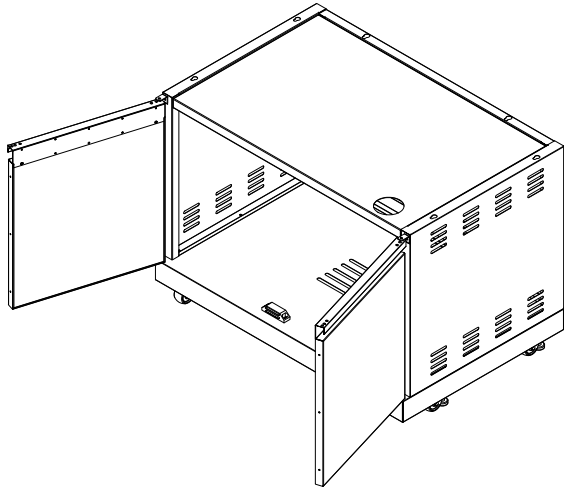

Cabinet connection: Connect each cabinet together by installing the screws if needed.

